

DRAWING LIST

| Design   | Dwg  | Description                  | Customer | Date   | REV        |
|--|------|------------------------------|----------|--------|------------|
| Mass DCR- Reservoir Boat- 24'x8'6" for Quabbin & Wachusett |      |                              |          |        |            |
| 544  | -1Q  | Outboard Profile, Quabbin    |          | 2/6/17 | R1, 4/5/17 |
|  | -1W  | Outboard Profile, Wachusett  |          | 2/6/17 | R1, 4/5/17 |
|  | -2Q  | Arrangement Plan, Quabbin    |          | 2/6/17 |            |
|  | -2W  | Arrangement Plan, Wachusett  |          | 2/6/17 |            |
|  | -3Q  | Inboard Profile, Quabbin     |          | 2/6/17 | R1, 4/5/17 |
|  | -3W  | Inboard Profile, Wachusett   |          | 2/6/17 | R1, 4/5/17 |
|  | -4Q  | End Views, Quabbin           |          | 2/6/17 | R1, 4/5/17 |
|  | -4W  | End Views, Wachusett         |          | 2/6/17 | R1, 4/5/17 |
|  | -5Q  | House Sections, Quabbin      |          | 2/6/17 | R1, 4/5/17 |
|  | -5W  | House Sections, Wachusett    |          | 2/6/17 | R1, 4/5/17 |
|  | 2-1Q | Keel Layout, Quabbin         |          | 4/3/17 |            |
|  | 2-1W | Keel Layout, Wachusett       |          | 4/3/17 |            |
|  | 2-2  | Bottom Layout                |          | 4/3/17 |            |
|  | 2-3Q | Transom & Splashwell         |          | 4/3/17 |            |
|  | 2-3W | Transoms, Wachusett          |          | 4/3/17 |            |
|  | 2-4Q | Bow, Quabbin                 |          | 4/3/17 |            |
|  | 2-4W | Bow, Wachusett               |          | 4/3/17 |            |
|  | 2-5Q | Side & Fore Decks, Quabbin   |          | 4/3/17 |            |
|  | 2-5W | Side & Fore Decks, Wachusett |          | 4/3/17 |            |
|  | 2-6Q | Cockpit Deck, Quabbin        |          | 4/3/17 |            |
|  | 2-6W | Cockpit Deck, Wachusett      |          | 4/3/17 |            |
|  | 2-7Q | Topside Stringers, Quabbin   |          | 4/3/17 |            |
|  | 2-7W | Topside Stringers, Wachusett |          | 4/3/17 |            |
|  | 5-1W | Bow Door, Wachusett          |          | 4/3/17 |            |
|  | B-1  | Flange Bending               |          | 4/3/17 |            |
|  | F-R  | Frame Dimensions             |          | 4/3/17 |            |
|  | F-1Q | Frame 1, Quabbin             |          | 4/3/17 |            |
|  | F-1W | Frame 1, Wachusett           |          | 4/3/17 |            |
|  | F-2Q | Frame 2, Quabbin             |          | 4/3/17 |            |
|  | F-2W | Frame 2, Wachusett           |          | 4/3/17 |            |
|  | F-3Q | Frame 3, WTBHD, Quabbin      |          | 4/3/17 |            |
|  | F-3W | Frame 3, WTBHD, Wachusett    |          | 4/3/17 |            |
|  | F-4  | Frame 4                      |          | 4/3/17 |            |
|  | F-5  | Frame 5                      |          | 4/3/17 |            |
|  | F-6Q | Frame 6, WTBHD, Quabbin      |          | 4/3/17 |            |
|  | F-6W | Frame 6, WTBHD, Wachusett    |          | 4/3/17 |            |
|  | F-7Q | Frame 7, Quabbin             |          | 4/3/17 |            |
|  | F-7W | Frame 7, Wachusett           |          | 4/3/17 |            |

Stock

Response Marine, Inc.  
#544, 24'x9' BB & LC, 2 Boats for Mass DCR  
HULLS ONLY

Stock List

3/8/2017

**SHEET/PLATE For NC Cutting (2 Boats)**

| <u>QTY</u>                 | <u>Alloy</u> | <u>Thick</u> | <u>Width</u> | <u>Lnqth</u> | approx.<br><u>lbs/ft^2</u> | <u>lbs</u> |
|----------------------------|--------------|--------------|--------------|--------------|----------------------------|------------|
| <b><u>PIERCE QUOTE</u></b> |              |              |              |              |                            |            |
| (PART COUNTS ARE ok)       |              |              |              |              |                            |            |
| 2                          | 5052         | 0.190        | 60           | 240          | 2.7                        | 540        |
| 1                          | 5052         | 0.190        | 72           | 240          | 2.7                        | 324        |
| 4                          | 5086         | 0.190        | 96           | 288          | 2.7                        | 2,074      |
| 1                          | 5086         | 0.190        | 84           | 288          | 2.7                        | 454        |
| 4                          | 5086         | 0.250        | 72           | 288          | 3.6                        | 2,074      |
| 1                          | 5086         | 0.250        | 60           | 240          | 3.6                        | 360        |
| 3                          | 5086         | 0.375        | 48           | 240          | 5.4                        | 1,296      |
| Total Plate for 2 Boats    |              |              |              |              |                            | 7,121      |

NC Parts

Response Marine, Inc.

NC Parts for #544 Mass DCR, 2 Boats  
 File: Mass DCR\544 Mass Parts, Dims & Stock  
 revised: 4/10/17

Print Date: 4/10/17

**HULL PARTS:**

**3/16" Parts- 5052- HULL**

| <u>Part #</u> | <u>Pieces</u> | <u>Description</u>                    | <u>Bend</u> |
|---------------|---------------|---------------------------------------|-------------|
| ALB-Q         | 1             | Anchor Locker Bottom, Quabbin         |             |
| BD-L          | 1             | Bow Doorway Lip, Wachusett            |             |
| BDR-3         | 1             | Bow Door Roller Top, Wachusett        |             |
| DB-AQ         | 1             | Deck Body F1-F3, Quabbin              |             |
| DB-BPQ        | 1             | Deck Body F3-F6, Port, Quabbin        |             |
| DB-BSQ        | 1             | Deck Body F3-F6, Stbd, Quabbin        |             |
| DB-CPQ        | 1             | Deck Body F6-Tran, Port, Quabbin      |             |
| DB-CSQ        | 1             | Deck Body F6-Tran, Stbd, Quabbin      |             |
| DB-CW         | 1             | Deck Body F6-F7+, Wachuset            |             |
| DM-APQ        | 1             | Deck Margin, Fwd of F3, Port Quabbin  |             |
| DM-ASQ        | 1             | Deck Margin, Fwd of F3, Stbd, Quabbin |             |
| DP-5          | 9             | Deck Plate 5, Cover                   |             |
| DP-5R         | 9             | Deck Plate 5, Ring                    |             |
| F1-D          | 2             | Frame 1 Doors, Quabbin                |             |
| FDC           | 1             | Foredeck Coaming, Quabbin             |             |
| FD-Q          | 1             | Foredeck, Quabbin                     |             |
| SPB           | 1             | Splashwell BHD & Coam                 |             |
| TD-P          | 1             | Transom Deck, Port, Quabbin           |             |
| TD-S          | 1             | Transom Deck, Stbd, Quabbin           |             |
| TD-W          | 1             | Transom Deck, Wachuset                |             |
|               | 37            | Sub Total                             |             |

**3/16" Parts- 5086**

| <u>Part #</u> | <u>Pieces</u> | <u>Description</u>                         |              |
|---------------|---------------|--|--------------|
| BOW-Q         | 1             | Bow, Quabbin                               | Y, As Marked |
| DB-AW         | 1             | Deck Body F1-F3, Wachuset                  |              |
| DB-BPW        | 1             | Deck Body F3-F6, Port, Wachuset            |              |
| DB-BSW        | 1             | Deck Body F3-F6, Stbd, Wachuset            |              |
| DB-DQ         | 1             | Deck Body Engine Well, Raised, Quabbin     |              |
| DB-DW         | 1             | Deck Body, Transom, Raised, Wachuset       |              |
| DM-APW        | 1             | Deck Margin, Fwd of F3, Port Wachuset      |              |
| DM-ASW        | 1             | Deck Margin, Fwd of F3, Stbd, Wachuset     |              |
| DM-BPQ        | 1             | Deck Margin, F3-Tran, Port, Quabbin        |              |
| DM-BPW        | 1             | Deck Margin, F3-F7+, Port, Wachuset        |              |
| DM-BSQ        | 1             | Deck Margin, F3-Tran, Stbd, Quabbin        |              |
| DM-BSW        | 1             | Deck Margin, F3-F7+, Stbd, Wachuset        |              |
| F1-Q          | 1             | Frame 1, Quabbin                           |              |
| F1U-PW        | 1             | Frame 1 Upper, Port, Above Deck, Wachusett |              |
| F1U-SW        | 1             | Frame 1 Upper, Stbd, Above Deck, Wachusett |              |

NC Parts

|          |   |  |   |                           |
|----------|---|--|---|---------------------------|
| F1-W     | 1 | Frame 1, Wachusett                               | Y | Flange B-1, <b>87 DEG</b> |
| F2-Q     | 1 | Frame 2, Quabbin                                 | Y | Flange B-1                |
| F2U-PQ   | 1 | Frame 2, Upper, Port, Quabbin                    | Y | Flange B-1                |
| F2U-PW   | 1 | Frame 2, Upper, Port, Wachusett                  | Y | Flange B-1                |
| F2U-SQ   | 1 | Frame 2, Upper, Stbd, Quabbin                    | Y | Flange B-1                |
| F2U-SW   | 1 | Frame 2, Upper, Stbd, Wachusett                  | Y | Flange B-1                |
| F2-W     | 1 | Frame 2, Wachusett                               | Y | Flange B-1, <b>87 DEG</b> |
| F3-Q     | 1 | Frame 3, Quabbin                                 | Y | Flange B-1                |
| F3-W     | 1 | Frame 3, Wachusett                               | Y | Flange B-1                |
| F4       | 2 | Frame 4  | Y | Flange B-1                |
| F4U-P    | 2 | Frame 4, Upper, Port                             | Y | Flange B-1                |
| F4U-S    | 2 | Frame 4, Upper, Stbd                             | Y | Flange B-1                |
| F5       | 2 | Frame 5  | Y | Flange B-1                |
| F5-UP    | 2 | Frame 5, Upper, Port                             | Y | Flange B-1                |
| F5-US    | 2 | Frame 5, Upper, Stbd                             | Y | Flange B-1                |
| F6-Q     | 1 | Frame 6, Quabbin                                 | Y | Flange B-1                |
| F6-W     | 1 | Frame 6, Wachusett                               | Y | Flange B-1                |
| F7-Q     | 1 | Frame 7, Quabbin                                 | Y | Flange B-1                |
| F7-W     | 1 | Frame 7, Wachusett                               | Y | Flange B-1                |
| FT       | 1 | False Transom, Wachusett                         |   |                           |
| SDC-APQ  | 1 | Side Deck Coaming, Fwd Port, Quabbin             |   |                           |
| SDC-APW  | 1 | Side Deck Coam, fwd jog, Port, Wachuset          |   |                           |
| SDC-ASQ  | 1 | Side Deck Coaming, Fwd Stbd, Quabbin             |   |                           |
| SDC-ASW  | 1 | Side Deck Coam, fwd jog, Stbd, Wachuset          |   |                           |
| SDC-BPQ  | 1 | Side Deck Coaming, house jog fwd Port, Quabbin   |   |                           |
| SDC-BPW  | 1 | Side Deck Coaming, house jog fwd Stbd, Wachusett |   |                           |
| SDC-BPW  | 1 | Side Deck Coam, Port, Wachuset                   |   |                           |
| SDC-BSW  | 1 | Side Deck Coam, Stbd, Wachuset                   |   |                           |
| SDC-CPQ  | 1 | Side Deck Coaming, house jog aft Port Quabbin    |   |                           |
| SDC-CSQ  | 1 | Side Deck Coaming, house jog aft Stbd Quabbin    |   |                           |
| SDC-CPW  | 1 | Side Deck Coam, house jog fwd, Port, Wachusett   |   |                           |
| SDC-CSW  | 1 | Side Deck Coam, house jog fwd, Stbd, Wachusett   |   |                           |
| SDC-DPQ  | 1 | Side Deck Coaming, Aft Port, Quabbin             |   |                           |
| SDC-DPS  | 1 | Side Deck Coaming, Aft Stbd, Quabbin             |   |                           |
| SD-PQ    | 1 | Side Deck, Port, Quabbin                         |   |                           |
| SD-PW    | 1 | Side Deck, Port, Wachuset                        |   |                           |
| SD-SQ    | 1 | Side Deck, Stbd, Quabbin                         |   |                           |
| SD-SW    | 1 | Side Deck, Stbd, Wachuset                        |   |                           |
| TK-P     | 2 | Transom Knee, Port, at BS1                       |   |                           |
| TK-S     | 2 | Transom Knee, Stbd, at BS1                       |   |                           |
| TSL-1APQ | 1 | TSL 1, fwd of F2, Port, Quabbin                  |   |                           |
| TSL-1APW | 1 | TSL 1, fwd of F2, Port, Wachuset                 |   |                           |
| TSL-1ASQ | 1 | TSL 1, fwd of F2, Stbd, Quabbin                  |   |                           |
| TSL-1ASW | 1 | TSL 1, fwd of F2, Stbd, Wachuset                 |   |                           |
| TSL-1BPQ | 1 | TSL 1, F2 to aft of F4, Port, Quabbin            |   |                           |
| TSL-1BPW | 1 | TSL 1, F2 to aft of F4, Port, Wachuset           |   |                           |
| TSL-1BSQ | 1 | TSL 1, F2 to aft of F4, Stbd, Quabbin            |   |                           |
| TSL-1BSW | 1 | TSL 1, F2 to aft of F4, Stbd, Wachuset           |   |                           |
| TSL-1CPQ | 1 | TSL 1, Aft of F4 to Tran, Port, Quabbin          |   |                           |
| TSL-1CPW | 1 | TSL 1, Aft of F4 to Tran, Port, Wachuset         |   |                           |
| TSL-1CSQ | 1 | TSL 1, Aft of F4 to Tran, Stbd, Quabbin          |   |                           |
| TSL-1CSW | 1 | TSL 1, Aft of F4 to Tran, Stbd, Wachuset         |   |                           |

NC Parts

|       |    |                           |
|-------|----|---------------------------|
| TS-PQ | 1  | Topsides, Port , Quabbin  |
| TS-PW | 1  | Topsides, Port , Wachuset |
| TS-SQ | 1  | Topsides, Stbd , Quabbin  |
| TS-SW | 1  | Topsides, Stbd , Wachuset |
|       | 79 | Sub Total                 |

**1/4" Parts- 5083/5086**

| <u>Part #</u> | <u>Pieces</u> | <u>Description</u>                       |              |
|---------------|---------------|--|--------------|
| BD            | 1             | Bow Door, Wachusett                      |              |
| BD-CP         | 1             | Bow Door Coaming/Locker, Port, Wachusett |              |
| BD-CS         | 1             | Bow Door Coaming/Locker, Stbd, Wachusett |              |
| BD-H3         | 4             | Bow Door Hinge Doubler, Wachusett        |              |
| BDP-1         | 3             | Bow Door Pipe Gusset, Wachusett          |              |
| BDP-2         | 2             | Bow Door Pipe Gusset/Cap, Wachusett      |              |
| BDR-1         | 1             | Bow Door Roller, IB, Wachusett           |              |
| BDR-2         | 1             | Bow Door Roller, OB, Wachusett           |              |
| BKD-P         | 2             | Bottom Keel Doubler, Port                |              |
| BKD-S         | 2             | Bottom Keel Doubler, Stbd                |              |
| BOW-S1        | 1             | Bow Stiffener- Lower Horiz, Quabbin      |              |
| BOW-S2        | 1             | Bow Stiffener- Upper Horiz, Quabbin      |              |
| BOW-S3        | 2             | Bow Stiffener- Vertical, Quabbin         |              |
| BOW-W         | 1             | Bow, Wachusett                           | Y, As Marked |
| B-P           | 2             | Bottom, Port                             |              |
| B-S           | 2             | Bottom, Stbd                             |              |
| BS-1P         | 2             | Bottom Longitudinal 1 Port               |              |
| BS-1S         | 2             | Bottom Longitudinal 1 Stbd               |              |
| BS-2P         | 2             | Bottom Longitudinal 2, Port              |              |
| BS-2S         | 2             | Bottom Longitudinal 2, Stbd              |              |
| BS-3P         | 2             | Bottom Longitudinal 3, Port              |              |
| BS-3S         | 2             | Bottom Longitudinal 3, Stbd              |              |
| BS-4P         | 2             | Bottom Longitudinal 4, Port              |              |
| BS-4S         | 2             | Bottom Longitudinal 4, Stbd              |              |
| TSL-2PQ       | 1             | TSL 2, fwd of F1, Port, Quabbin          |              |
| TSL-2PW       | 1             | TSL 2, fwd of F1, Port, Wachuset         |              |
| TSL-2SQ       | 1             | TSL 2, fwd of F1, Stbd, Quabbin          |              |
| TSL-2SW       | 1             | TSL 2, fwd of F1, Stbd, Wachuset         |              |
| TU-Q          | 1             | Transom, Upper, Quabbin                  |              |
|               | 48            | Sub Total                                |              |

**3/8" Parts-5083/5086**

| <u>Part #</u> | <u>Pieces</u> | <u>Description</u>              |
|---------------|---------------|---------------------------------|
| BD-H1         | 8             | Bow Door Hinge, Boat, Wachusett |
| BD-H2         | 4             | Bow Door Hinge, Door, Wachusett |
| C-AP          | 2             | Chine, Fwd Port                 |
| C-AS          | 2             | Chine, Fwd Stbd                 |
| C-BP          | 2             | Chine, Aft Port                 |
| C-BS          | 2             | Chine, Aft Stbd                 |
| DVE           | 6             | Davit Eyes with & w/o holes     |
| K-A-Q         | 1             | Keel, Fwd, Quabbin              |
| K-A-W         | 1             | Keel, Fwd, Wachuset             |
| K-B-Q         | 1             | Keel, Aft, Quabbin              |
| K-B-W         | 1             | Keel, Aft, Wachuset             |
| K-S-Q         | 1             | Keel, Stem Quabbin              |
| TL-Q          | 1             | Transom Lip, Quabbin            |

NC Parts

|      |     |                                   |
|------|-----|-----------------------------------|
| TL-W | 1   | Transom Lip, Wachuset             |
| TR-Q | 1   | Transom, Quabbin                  |
| TR-W | 1   | Transom, Wachuset                 |
|      | 35  | Sub Total                         |
|      | 199 | Total Cut Parts (Hull, w/o house) |

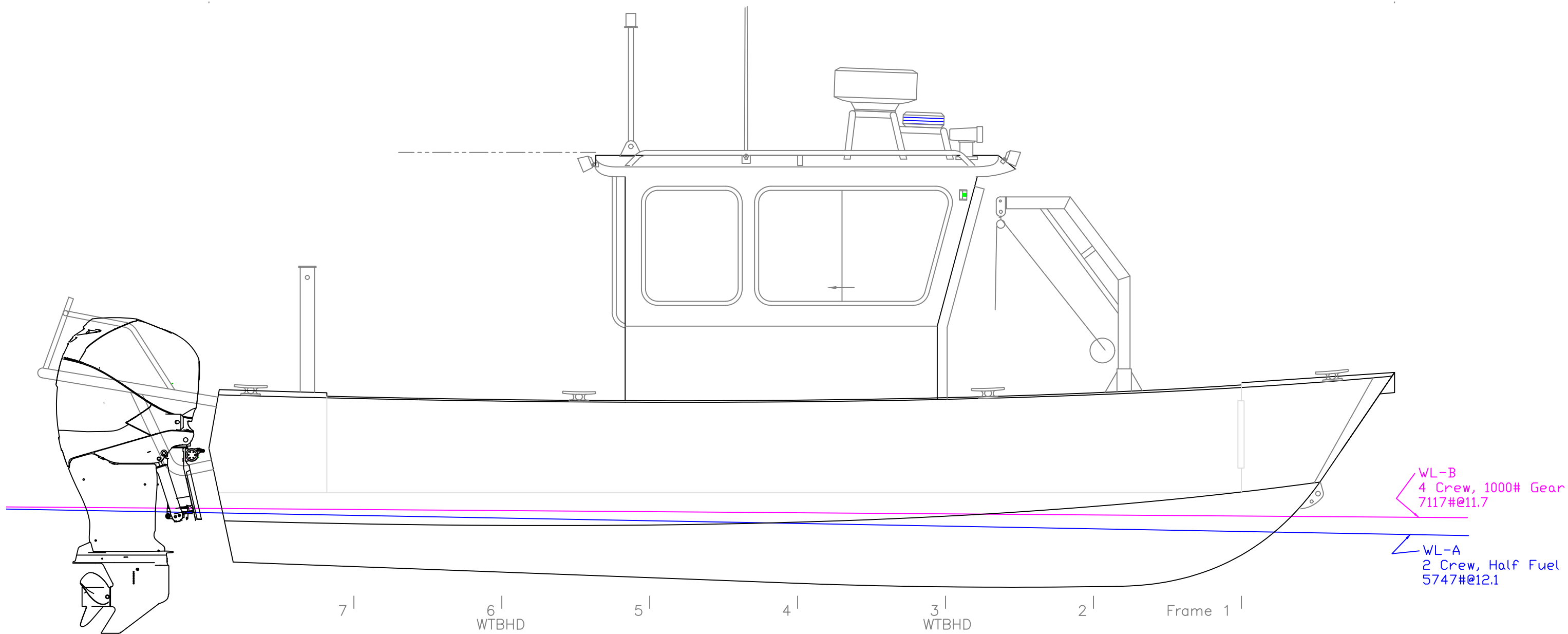

Boat #1, Quabbin

OUTBOARD PROFILE

Response #544-24'x9' BB

|                    |                    |                |
|--------------------|--------------------|----------------|
| SCALE<br>1/2" = 1' | DES/DWN<br>WAL/JCC | DATE<br>2/6/17 |
|--------------------|--------------------|----------------|

|   |  |
|---|--|
| <b>Response Marine, Inc.</b><br>Newburyport, MA, <a href="http://www.responsemarine.com">www.responsemarine.com</a> | Rev<br>R1, 4/5/17<br>DWG NO.<br>544-Q1 |
|---|--|

| REV.        | DESCRIPTION        |
|-------------|--------------------|
| R1, 4/5/17, | Raised Tow Post 6" |



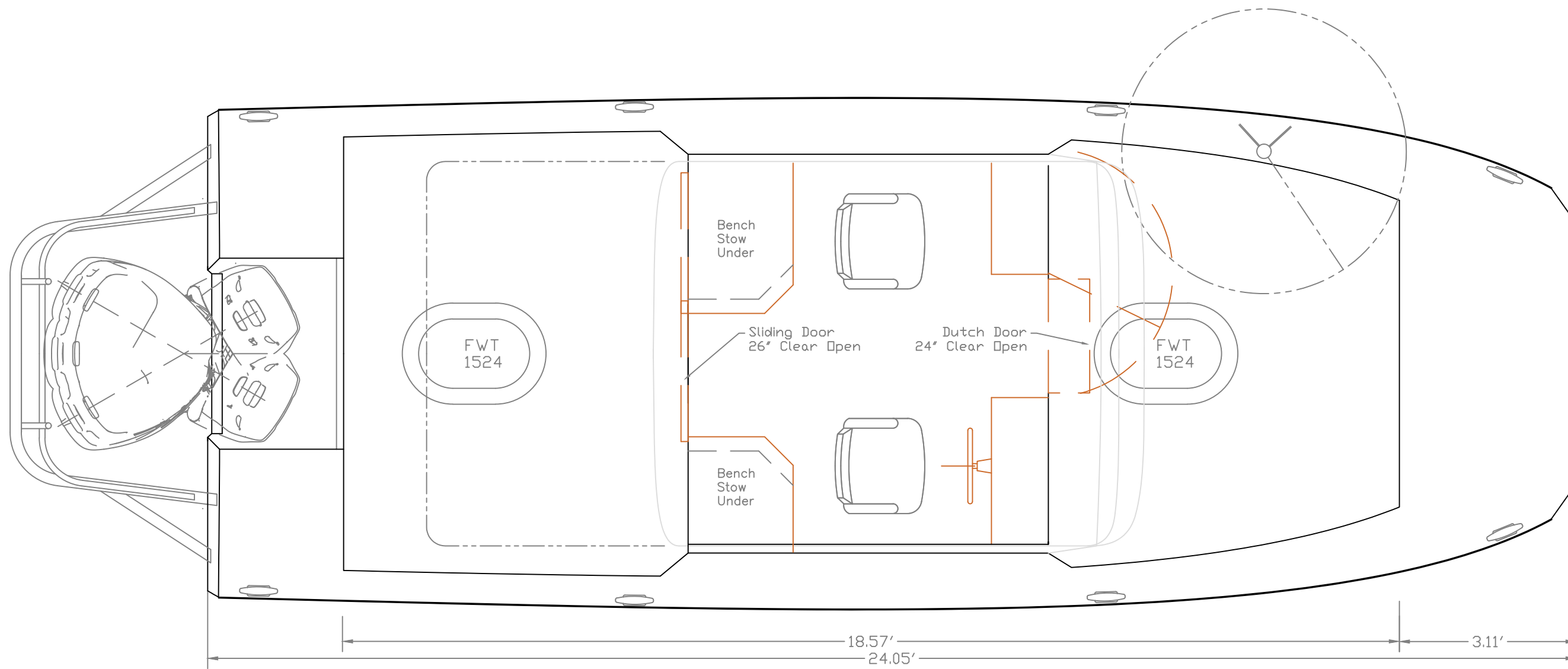

Boat #1, Quabbin

ARRANGEMENT PLAN

Response #544-24'x9' BB

|                    |                    |                |
|--------------------|--------------------|----------------|
| SCALE<br>1/2" = 1' | DES/DWN<br>WAL/JCC | DATE<br>2/6/17 |
|--------------------|--------------------|----------------|

|   |                   |       |
|---|-------------------|-------|
| <b>Response Marine, Inc.</b>  |                   | SHEET |
| Newburyport, MA, <a href="http://www.responsemarine.com">www.responsemarine.com</a> | DWG NO.<br>544-Q2 |       |

| REV. | DESCRIPTION |
|------|-------------|
|      |             |

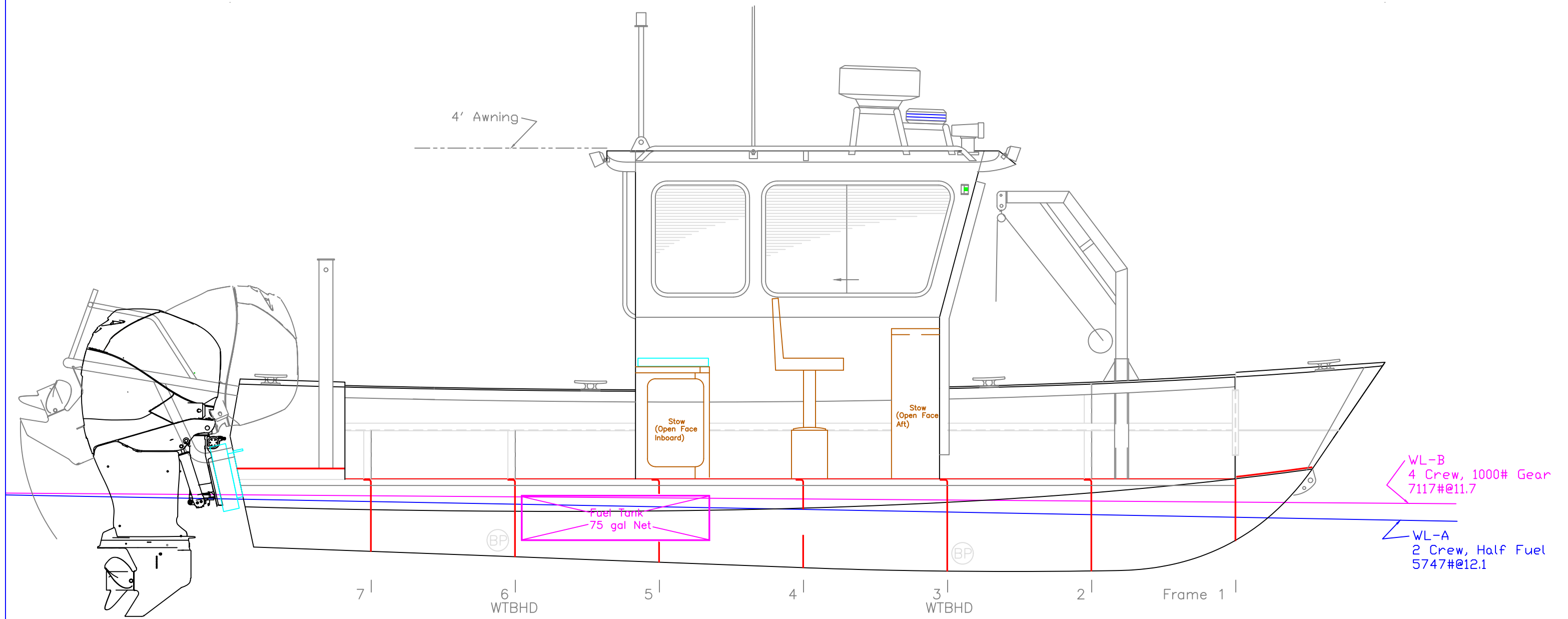

Boat #1, Quabbin

INBOARD PROFILE

Response #544-24'x9' BB

|                    |                    |                |
|--------------------|--------------------|----------------|
| SCALE<br>1/2" = 1' | DES/DWN<br>WAL/JCC | DATE<br>2/6/17 |
|--------------------|--------------------|----------------|

|                   |
|-------------------|
| Rev<br>R1, 4/5/17 |
|-------------------|

|                   |
|-------------------|
| DWG NO.<br>544-Q3 |
|-------------------|

| REV.        | DESCRIPTION        |
|-------------|--------------------|
| R1, 4/5/17, | Raised Tow Post 6" |

**Response Marine, Inc.**  
Newburyport, MA, www.responsemarine.com

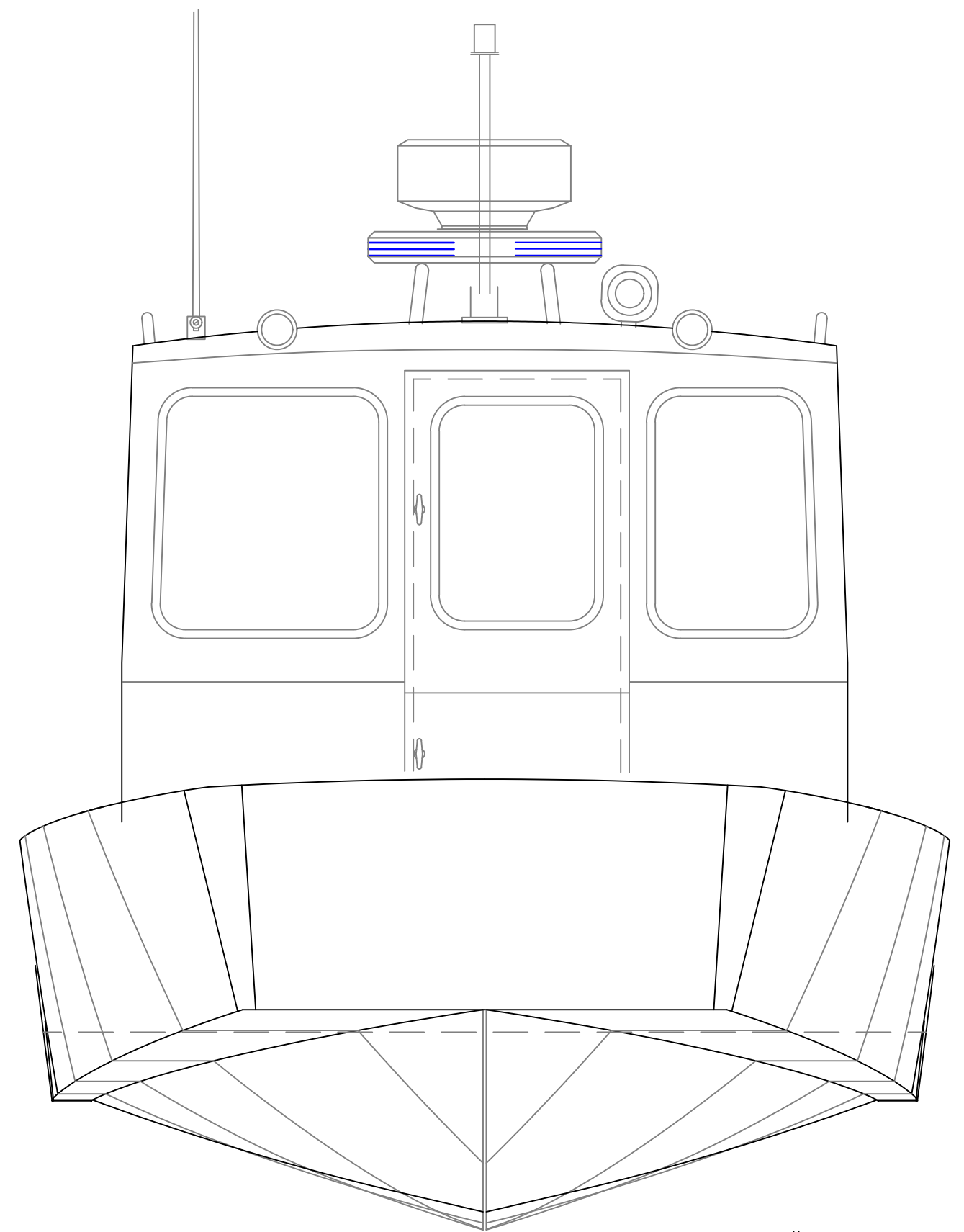
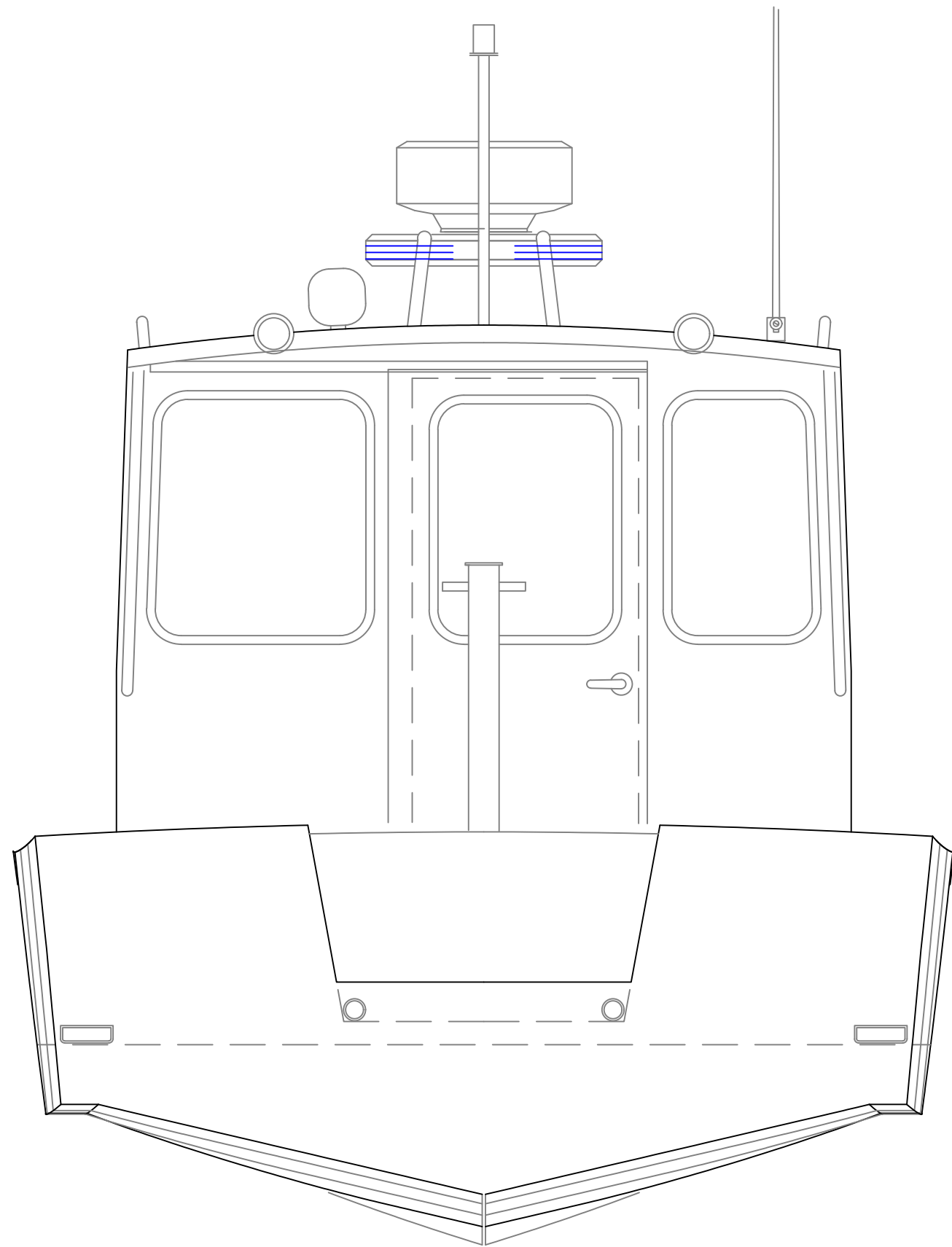

Boat #1, Quabbin

END VIEWS

Response #544-24'x9' BB

|                    |                    |                |
|--------------------|--------------------|----------------|
| SCALE<br>3/4" = 1' | DES/DWN<br>WAL/JCC | DATE<br>2/6/17 |
|--------------------|--------------------|----------------|

|                   |
|-------------------|
| Rev<br>R1, 4/5/17 |
|-------------------|

|                   |
|-------------------|
| DWG NO.<br>544-Q4 |
|-------------------|

| REV.        | DESCRIPTION        |
|-------------|--------------------|
| R1, 4/5/17, | Tow Post, Aft Door |

**Response Marine, Inc.**  
Newburyport, MA, [www.responsemarine.com](http://www.responsemarine.com)

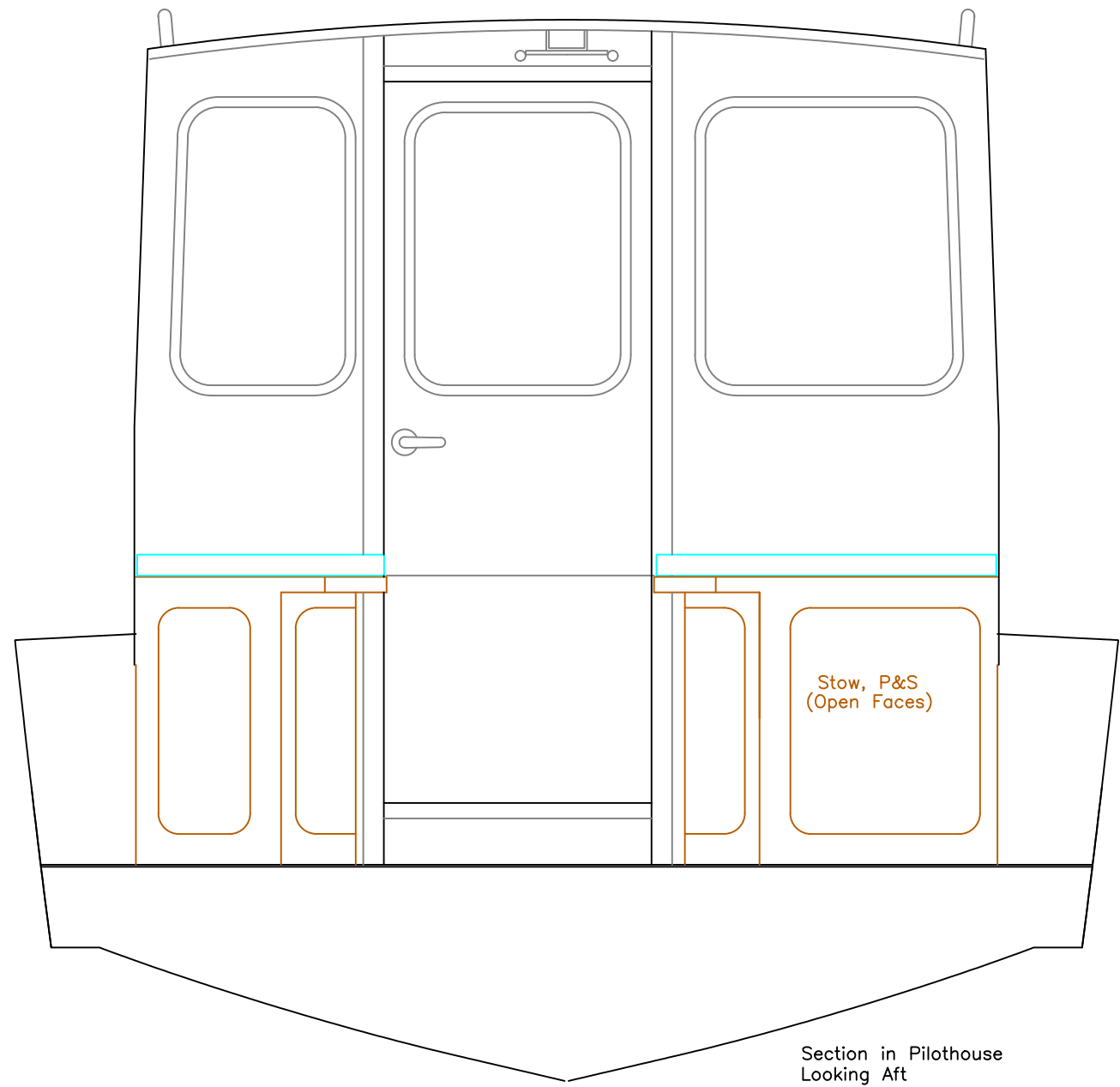

Section in Pilothouse  
Looking Aft

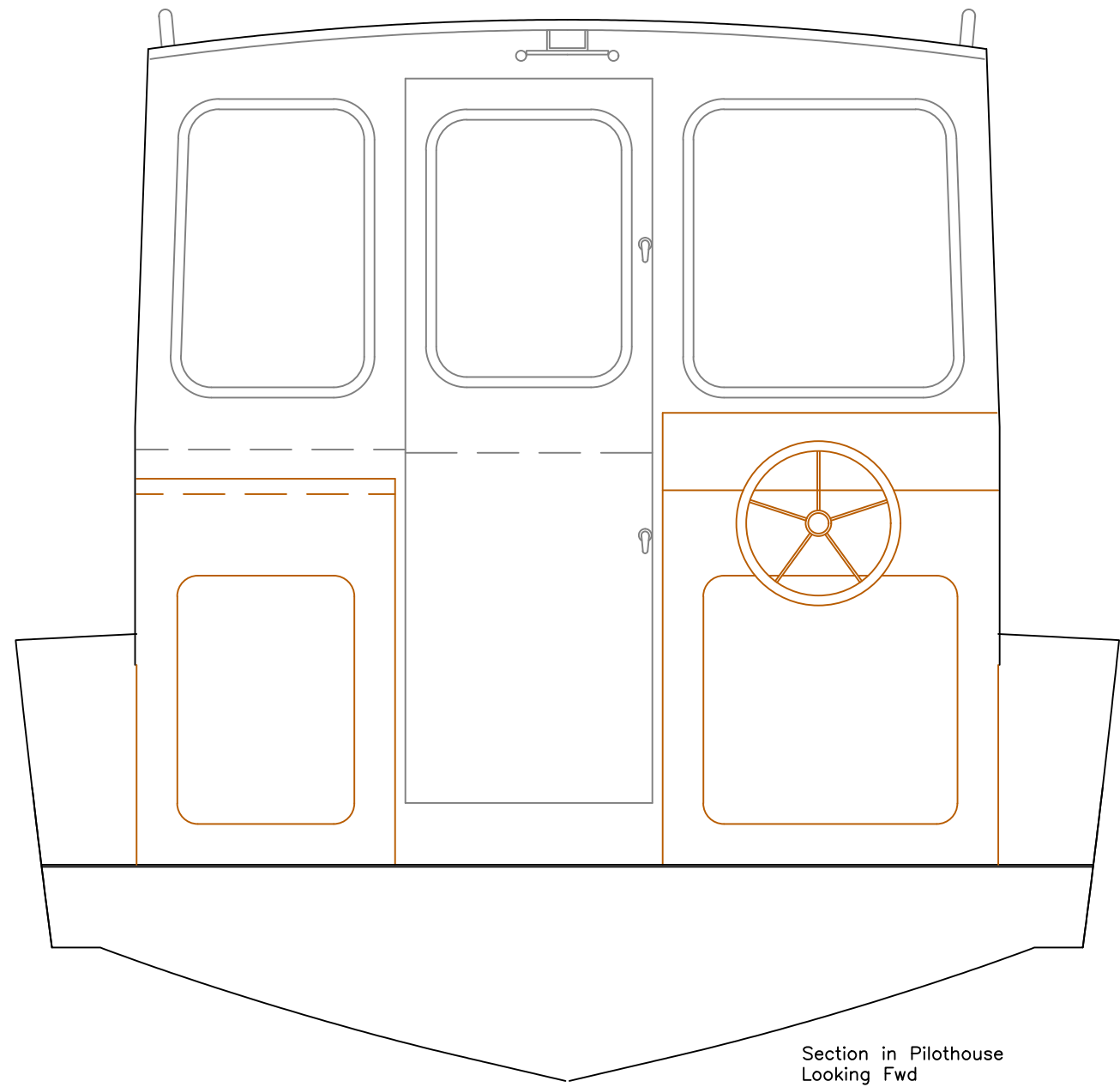

Section in Pilothouse  
Looking Fwd

Boat #1, Quabbin

HOUSE SECTIONS

Response #544-24'x9' BB

|                    |                    |                |
|--------------------|--------------------|----------------|
| SCALE<br>3/4" = 1' | DES/DWN<br>WAL/JCC | DATE<br>2/6/17 |
|--------------------|--------------------|----------------|

Rev R1, 4/5/17

DWG NO. 544-Q5

| REV.        | DESCRIPTION       |
|-------------|-------------------|
| R1, 4/5/17, | Bench Faces, Door |

**Response Marine, Inc.**  
Newburyport, MA, [www.responsemarine.com](http://www.responsemarine.com)

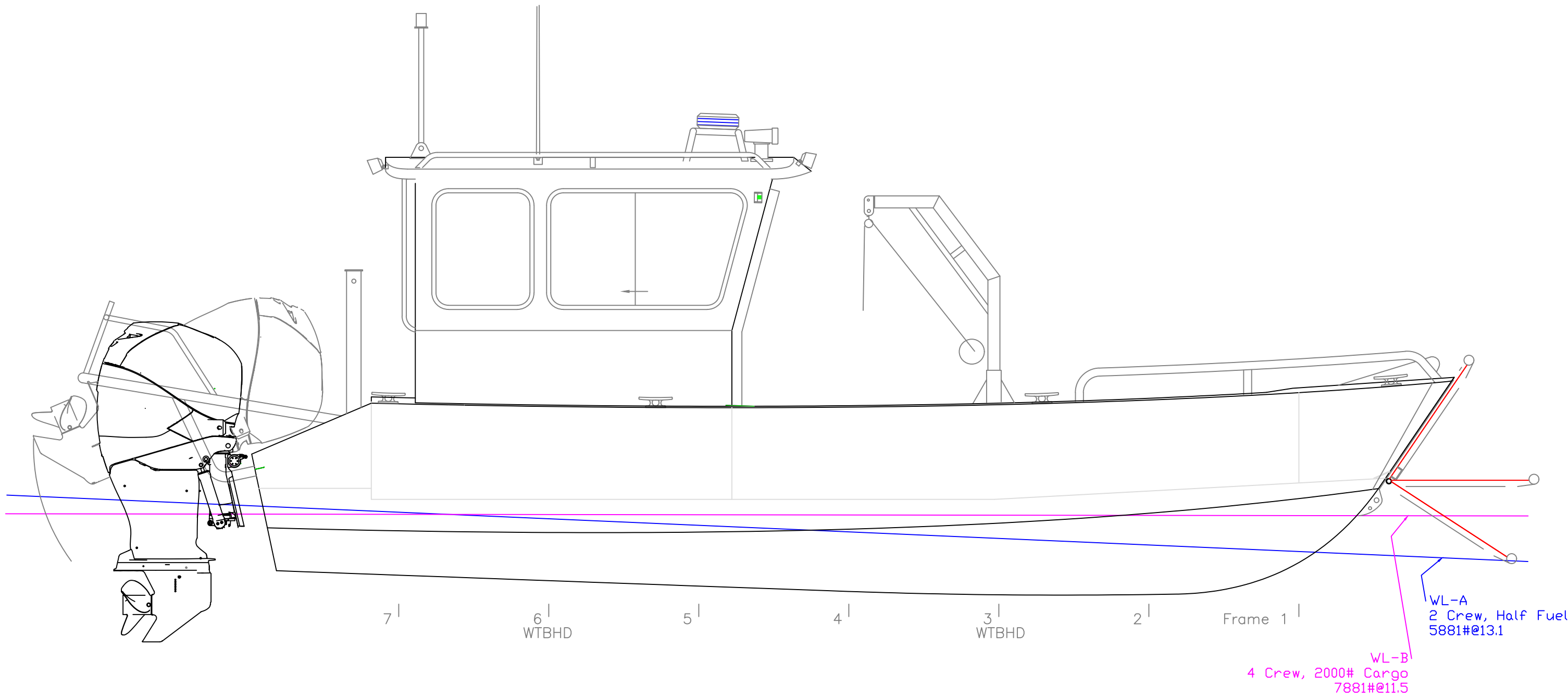

WL-A  
2 Crew, Half Fuel  
5881#@13.1

WL-B  
4 Crew, 2000# Cargo  
7881#@11.5

Boat #2, Wachusett

OUTBOARD PROFILE

Response #544-24'x9' LC

|                    |                    |                |
|--------------------|--------------------|----------------|
| SCALE<br>1/2" = 1' | DES/DWN<br>WAL/JCC | DATE<br>2/6/17 |
|--------------------|--------------------|----------------|

Rev R1, 4/5/17  
DWG NO. 544-W1

| REV.        | DESCRIPTION        |
|-------------|--------------------|
| R1, 4/5/17, | Raised Tow Post 6" |

**Response Marine, Inc.**  
Newburyport, MA, www.responsemarine.com

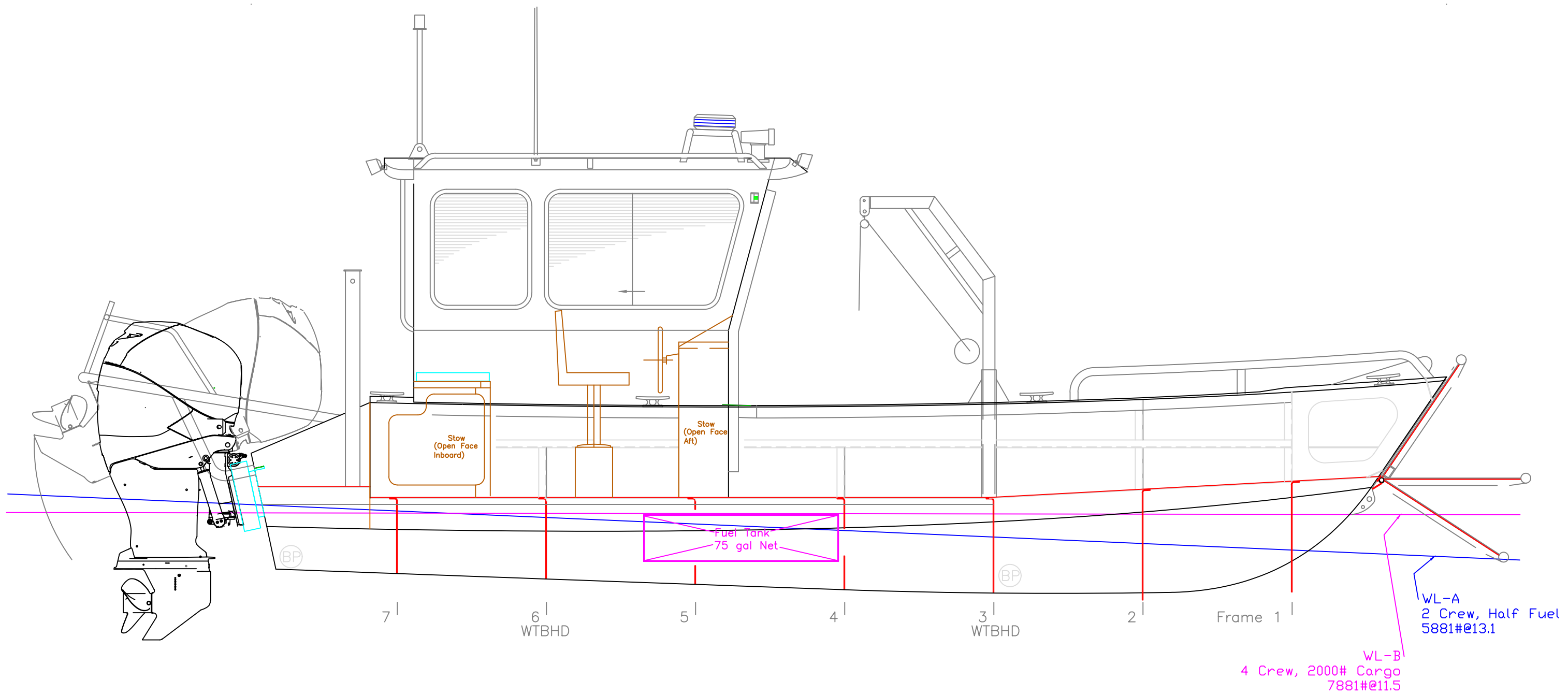

WL-A  
2 Crew, Half Fuel  
5881#@13.1

WL-B  
4 Crew, 2000# Cargo  
7881#@11.5

Boat #2, Wachusett

INBOARD PROFILE

Response #544-24'x9' LC

|                    |                    |                |
|--------------------|--------------------|----------------|
| SCALE<br>1/2" = 1' | DES/DWN<br>WAL/JCC | DATE<br>2/6/17 |
|--------------------|--------------------|----------------|

|                   |                   |
|-------------------|-------------------|
| Rev<br>R1, 4/5/17 | DWG NO.<br>544-W3 |
|-------------------|-------------------|

| REV.        | DESCRIPTION        |
|-------------|--------------------|
| R1, 4/5/17, | Raised Tow Post 6" |

**Response Marine, Inc.**  
Newburyport, MA, www.responsemarine.com

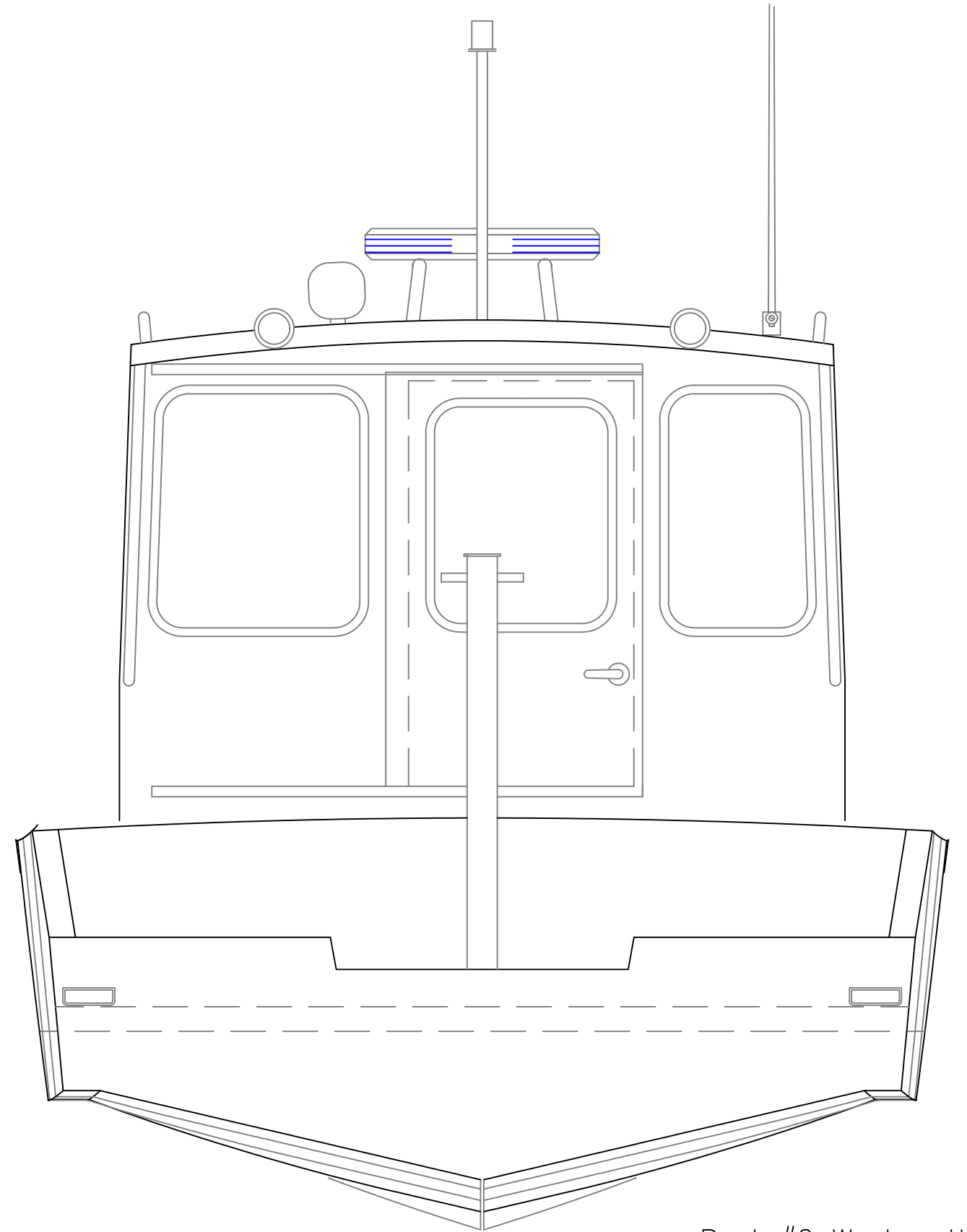
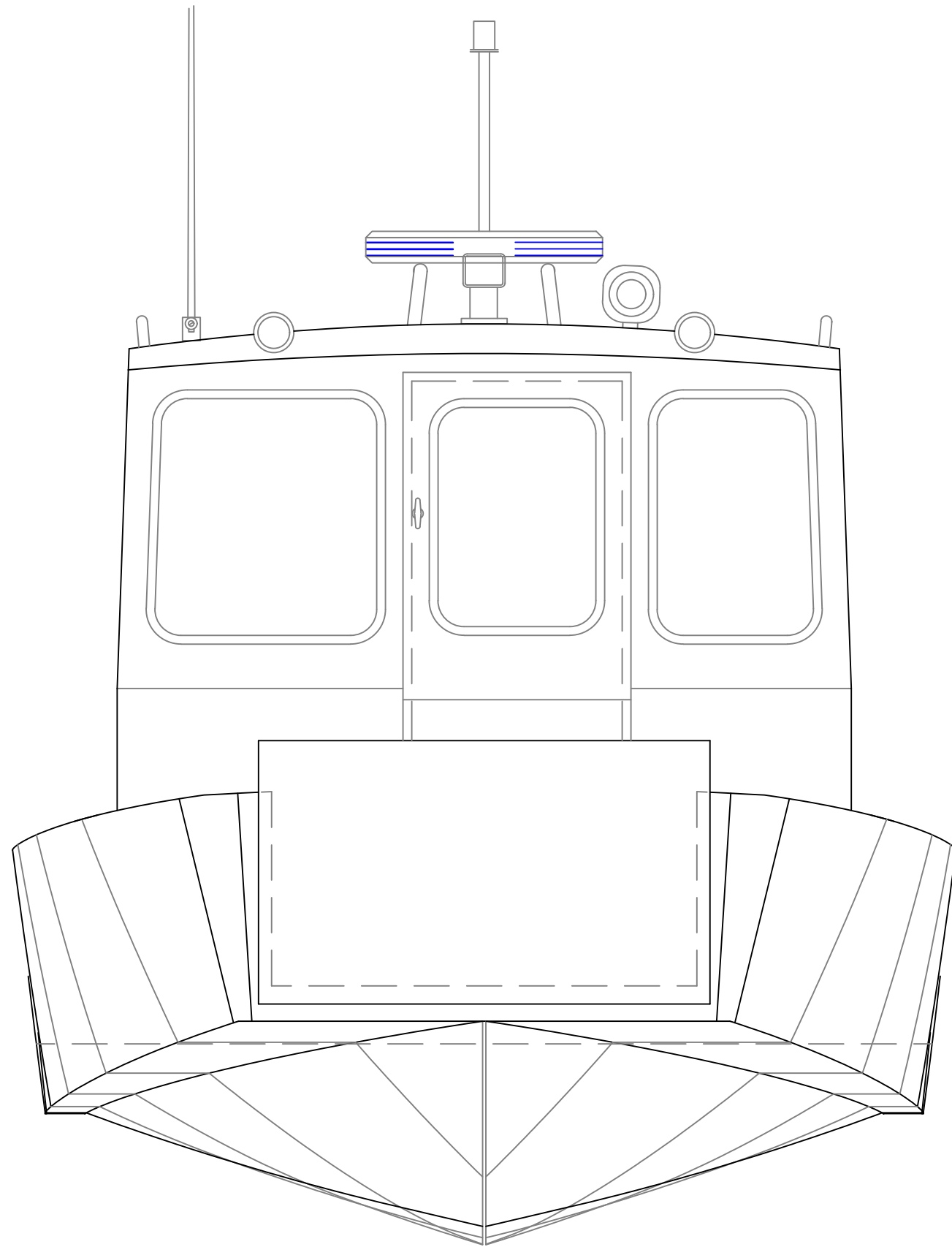

Boat #2 Wachusett

END VIEWS

Response #544-24'x9' LC

|                    |                    |                |
|--------------------|--------------------|----------------|
| SCALE<br>3/4" = 1' | DES/DWN<br>WAL/JCC | DATE<br>2/6/17 |
|--------------------|--------------------|----------------|

|                   |
|-------------------|
| Rev<br>R1, 4/5/17 |
|-------------------|

|  |                   |
|--|-------------------|
| Response Marine, Inc.<br>Newburyport, MA, www.responsemarine.com | DWG NO.<br>544-W4 |
|--|-------------------|

| REV.        | DESCRIPTION        |
|-------------|--------------------|
| R1, 4/5/17, | Tow Post, Aft Door |

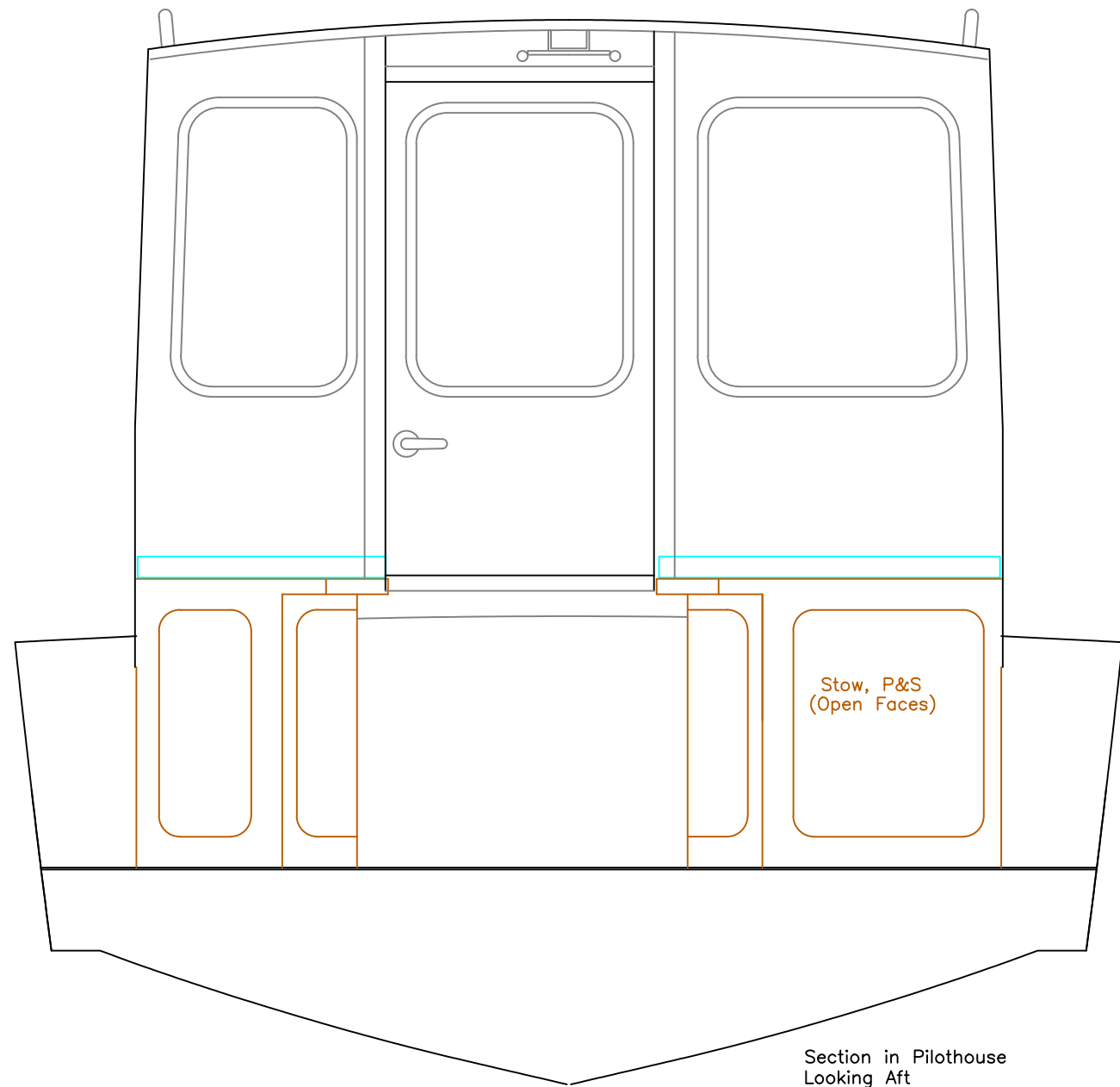

Section in Pilothouse  
Looking Aft

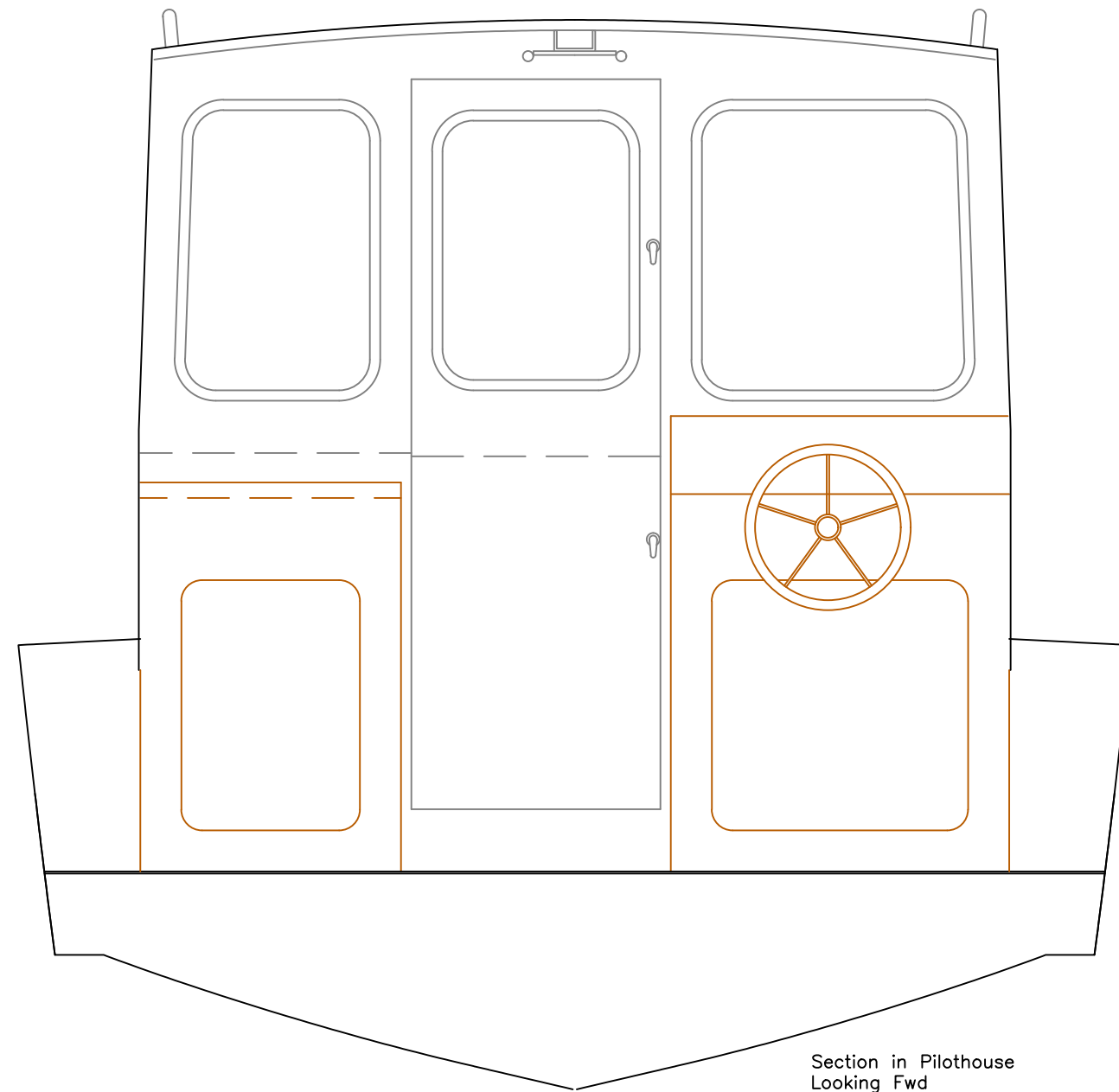

Section in Pilothouse  
Looking Fwd

Boat #2, Wachusett

HOUSE SECTIONS

Response #544-24'x9' LC

|                    |                    |                |
|--------------------|--------------------|----------------|
| SCALE<br>3/4" = 1' | DES/DWN<br>WAL/JCC | DATE<br>2/6/17 |
|--------------------|--------------------|----------------|

Rev R1, 4/5/17  
DWG NO. 544-W5

| REV.        | DESCRIPTION |
|-------------|-------------|
| R1, 4/5/17, | Bench Faces |

**Response Marine, Inc.**  
Newburyport, MA, www.responsemarine.com



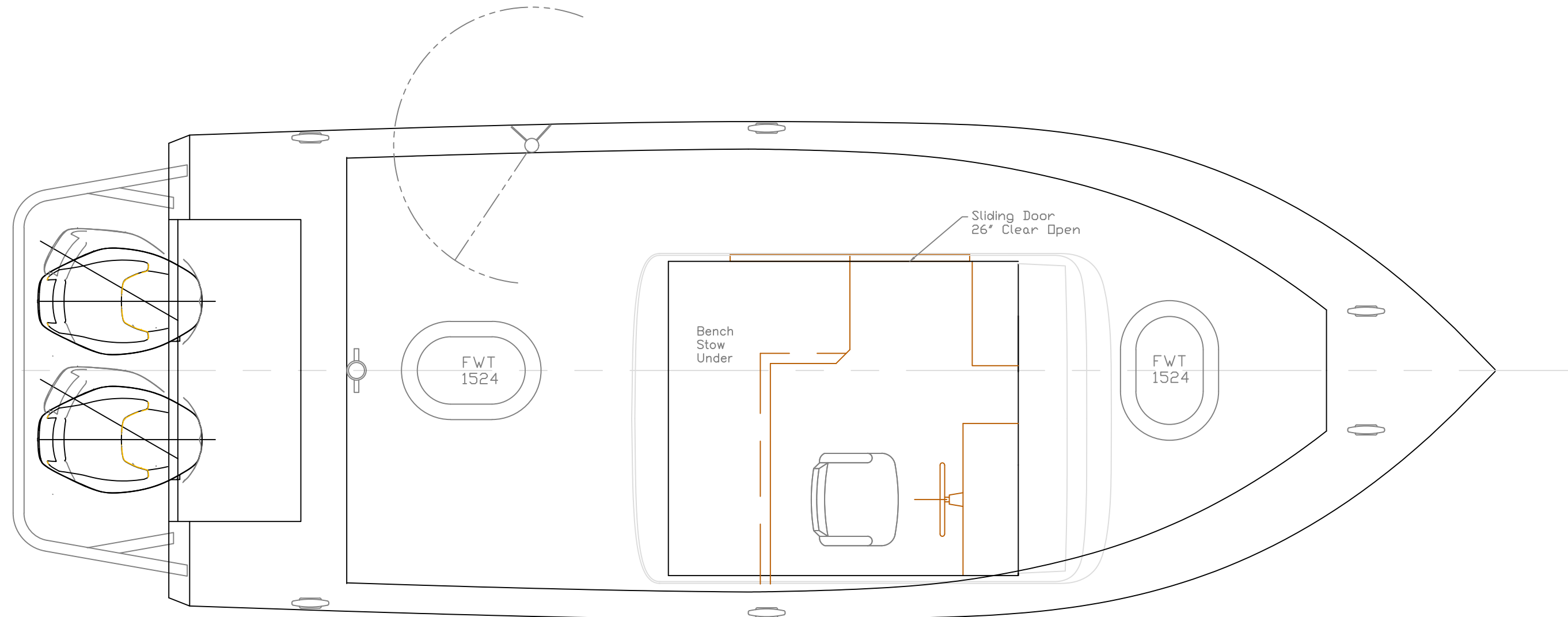

Optional House Layout  
& Traditional Bow

Alt. Plan, 24'x9'

Response #544-

|                    |                |                  |
|--------------------|----------------|------------------|
| SCALE<br>1/2" = 1' | DES/DWN<br>WAL | DATE<br>11/16/16 |
|--------------------|----------------|------------------|

|       |  |
|-------|--|
| SHEET |  |
|-------|--|

|                              |                   |
|------------------------------|-------------------|
| <b>Response Marine, Inc.</b> | DWG NO.<br>544-P2 |
|------------------------------|-------------------|

Newburyport, MA, [www.responsemarine.com](http://www.responsemarine.com)

Note: Drawing may depict some items bid as Options.  
Alternate House Arrangements & Locations are available

|      |                    |
|------|--------------------|
| REV. | DESCRIPTION        |
|      | <b>PRELIMINARY</b> |

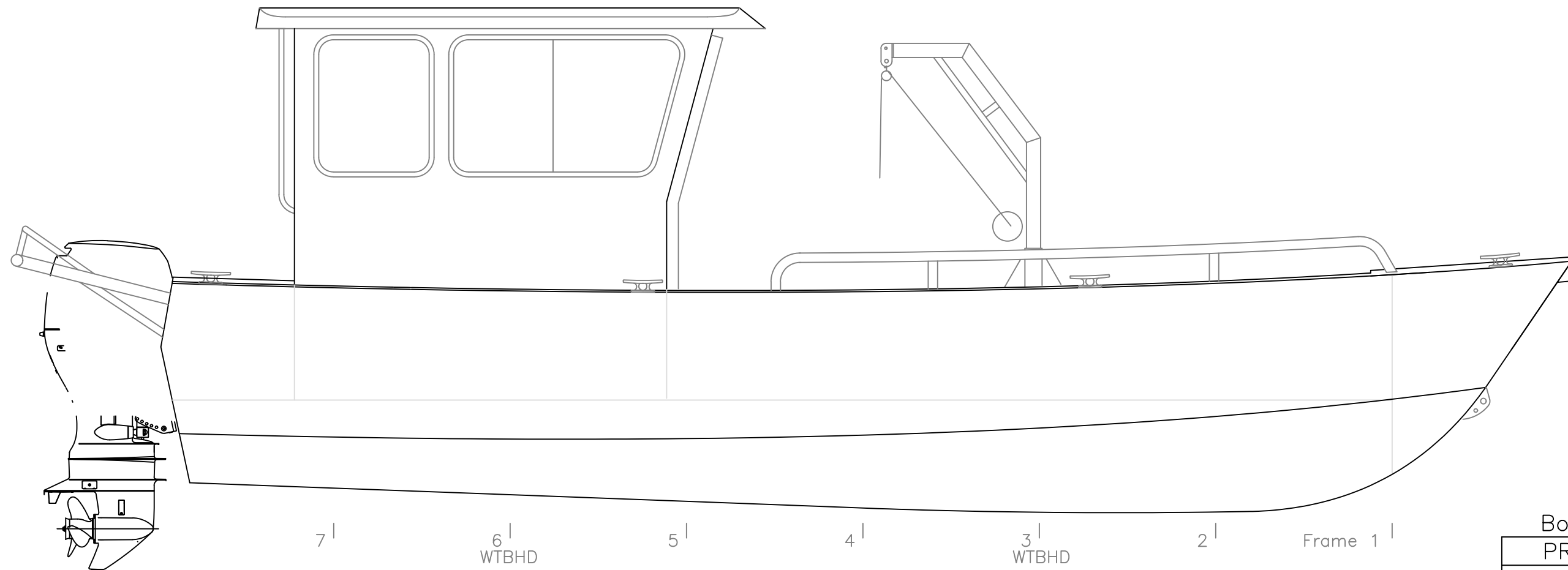
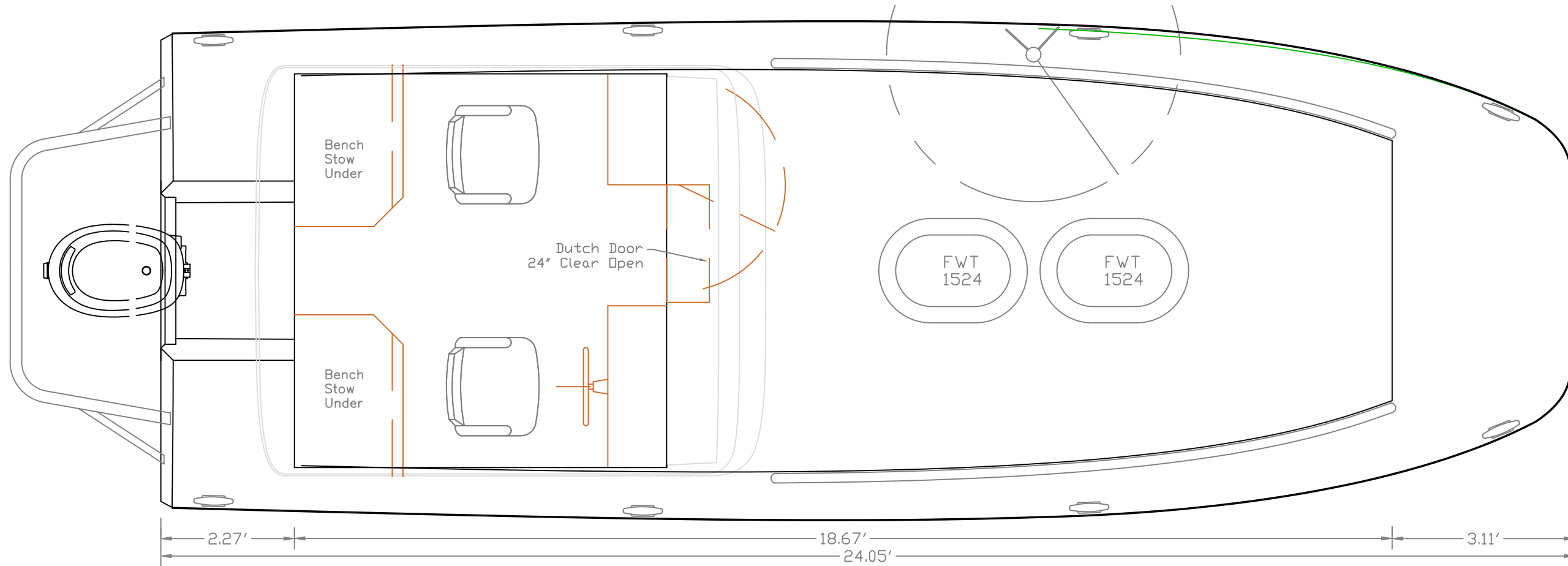

Note: Drawing may depict some items bid as Options.  
 Alternate House Arrangements & Locations are available

REV. DESCRIPTION  
**PRELIMINARY**

|   |                |                   |
|---|----------------|-------------------|
| Boat #2, Wachusett                      |                |                   |
| PROFILE & PLAN                          |                |                   |
| Response #544-24'x8.5' BB               |                |                   |
| SCALE<br>1/2" = 1'                      | DES/DWN<br>WAL | DATE<br>11/15/16  |
| Response Marine, Inc.                   |                | SHEET             |
| Newburyport, MA, www.responsemarine.com |                | DWG NO.<br>544-P3 |

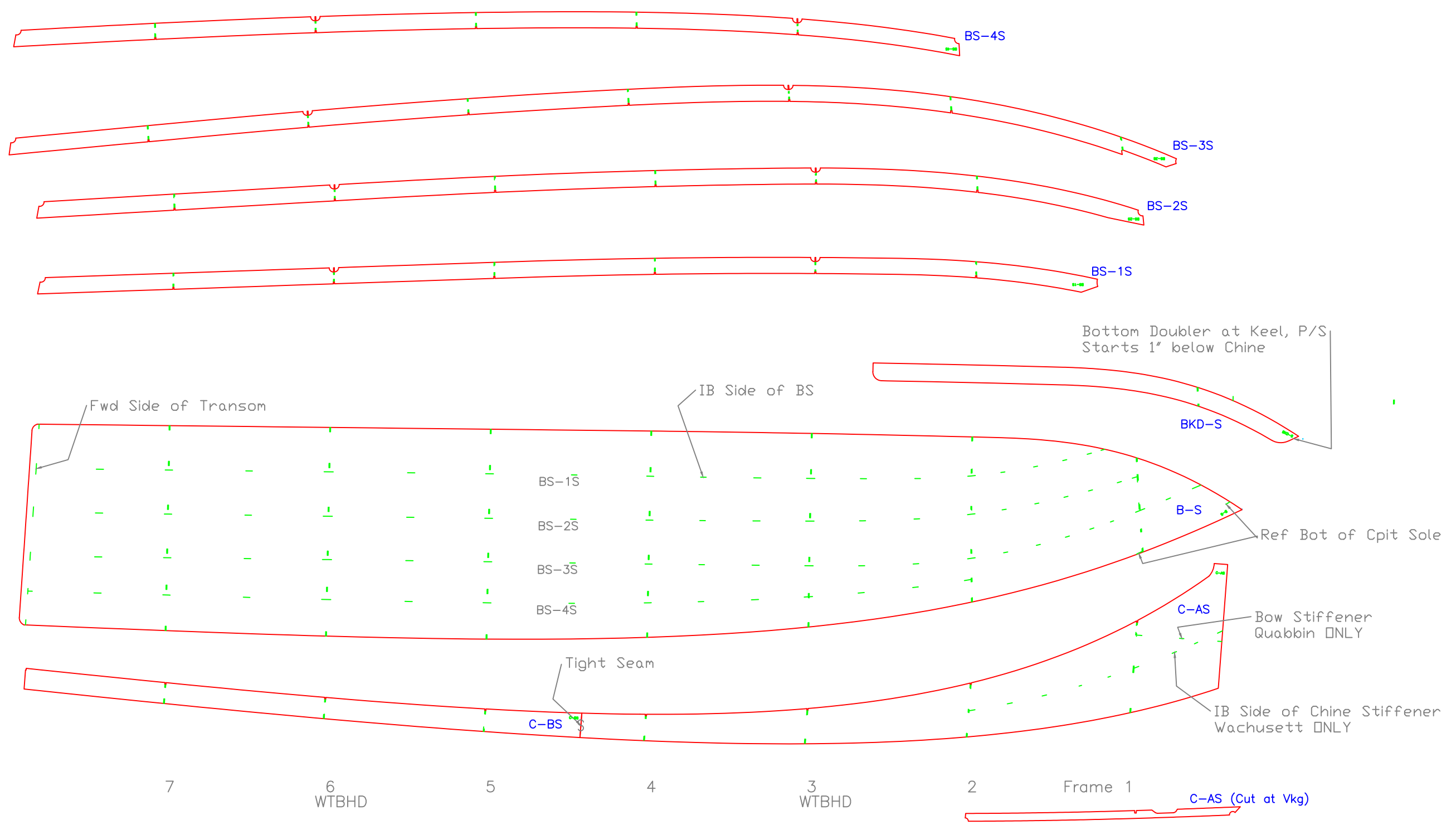

|  |                    |                    |
|--|--------------------|--------------------|
| Quabbin & Wachusett                    |                    |                    |
| BOTTOM LAYOUT                          |                    |                    |
| Response #544-24'x9' BB                |                    |                    |
| SCALE<br>1/2" = 1'                     | DES/DWN<br>WAL/JCC | DATE<br>4/3/17     |
| <b>Response Marine, Inc.</b>           |                    | SHEET              |
| Newburyport, MA www.responsemarine.com |                    | DWG NO.<br>544-2-2 |

| REV. | DESCRIPTION |
|------|-------------|
|      |             |

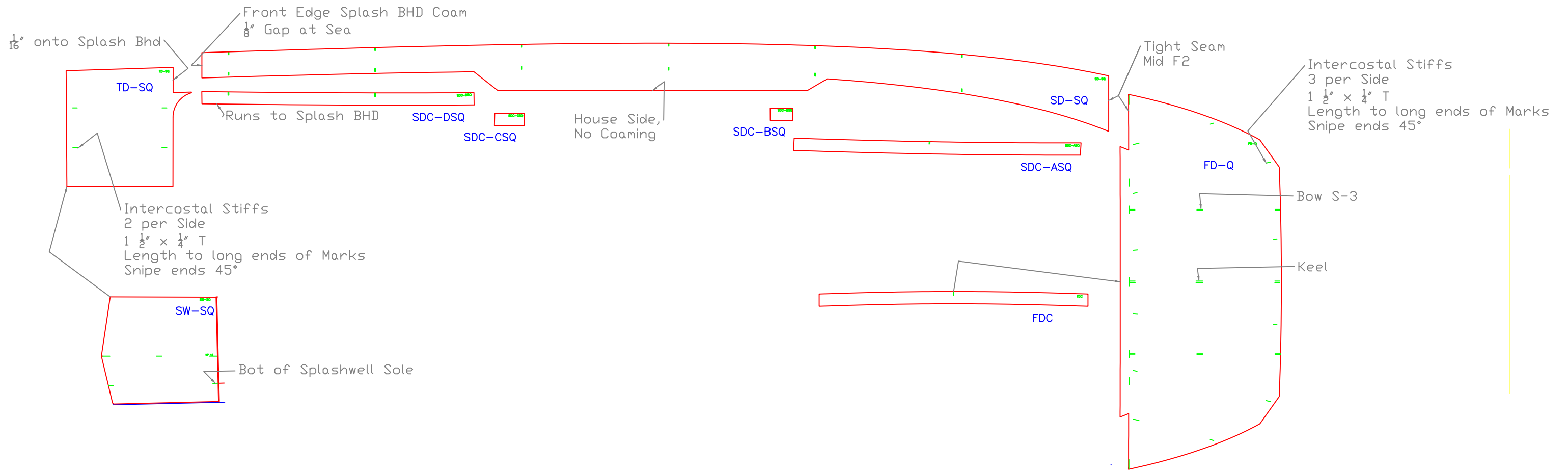

|  |         |        |                     |
|--|---------|--------|---------------------|
| Boat #1, Quabbin                       |         |        |                     |
| SIDE & FORE DECKS                      |         |        |                     |
| Response #544-24'x9' BB                |         |        |                     |
| SCALE                                  | DES/DWN | DATE   |                     |
| 1/2" = 1'                              | WAL/JCC | 4/3/17 |                     |
| Response Marine, Inc.                  |         |        | SHEET               |
| Newburyport, MA www.responsemarine.com |         |        | DWG NO.<br>544-2-5Q |

| REV. | DESCRIPTION |
|------|-------------|
|      |             |

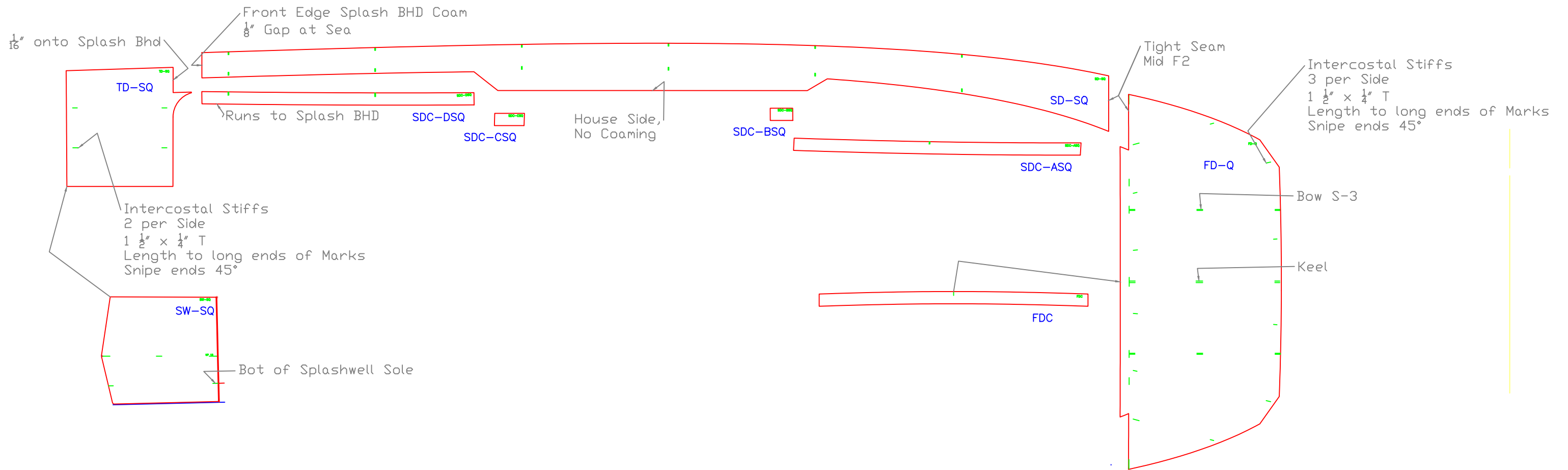

Boat #2, Wachusett

SIDE & FORE DECKS

Response #544-24'x9' LC

|                    |                    |                |
|--------------------|--------------------|----------------|
| SCALE<br>1/2" = 1' | DES/DWN<br>WAL/JCC | DATE<br>4/3/17 |
|--------------------|--------------------|----------------|

|                              |       |
|------------------------------|-------|
| <b>Response Marine, Inc.</b> | SHEET |
|------------------------------|-------|

|   |                     |
|---|---------------------|
| Newburyport, MA<br>www.responsemarine.com | DWG NO.<br>544-2-5W |
|---|---------------------|

| REV. | DESCRIPTION |
|------|-------------|
|      |             |

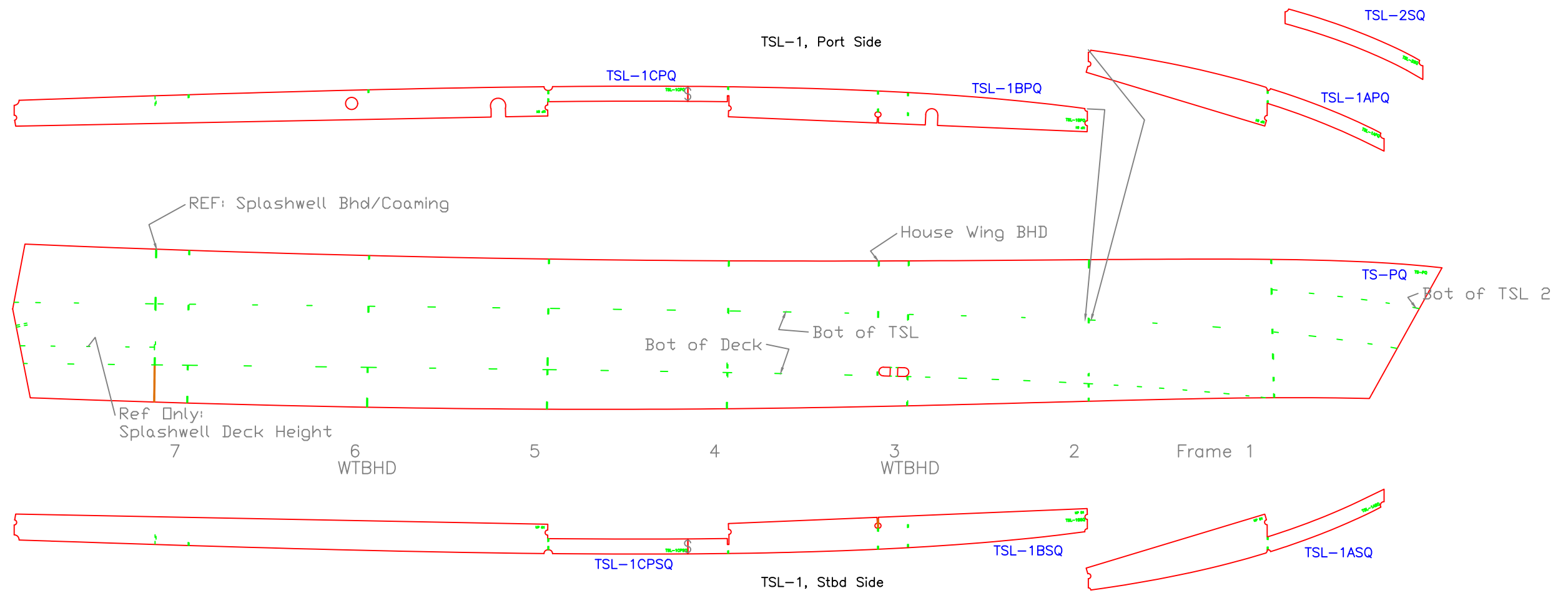

|  |                    |                     |
|--|--------------------|---------------------|
| Boat #1, Quabbin                       |                    |                     |
| TOPSIDES PL & STRINGERS                |                    |                     |
| Response #544-24'x9' BB                |                    |                     |
| SCALE<br>1/2" = 1'                     | DES/DWN<br>WAL/JCC | DATE<br>4/3/17      |
| <b>Response Marine, Inc.</b>           |                    | SHEET               |
| Newburyport, MA www.responsemarine.com |                    | DWG NO.<br>544-2-7Q |

| REV. | DESCRIPTION |
|------|-------------|
|      |             |

Install w/  
Marks & Flange on AFT Side

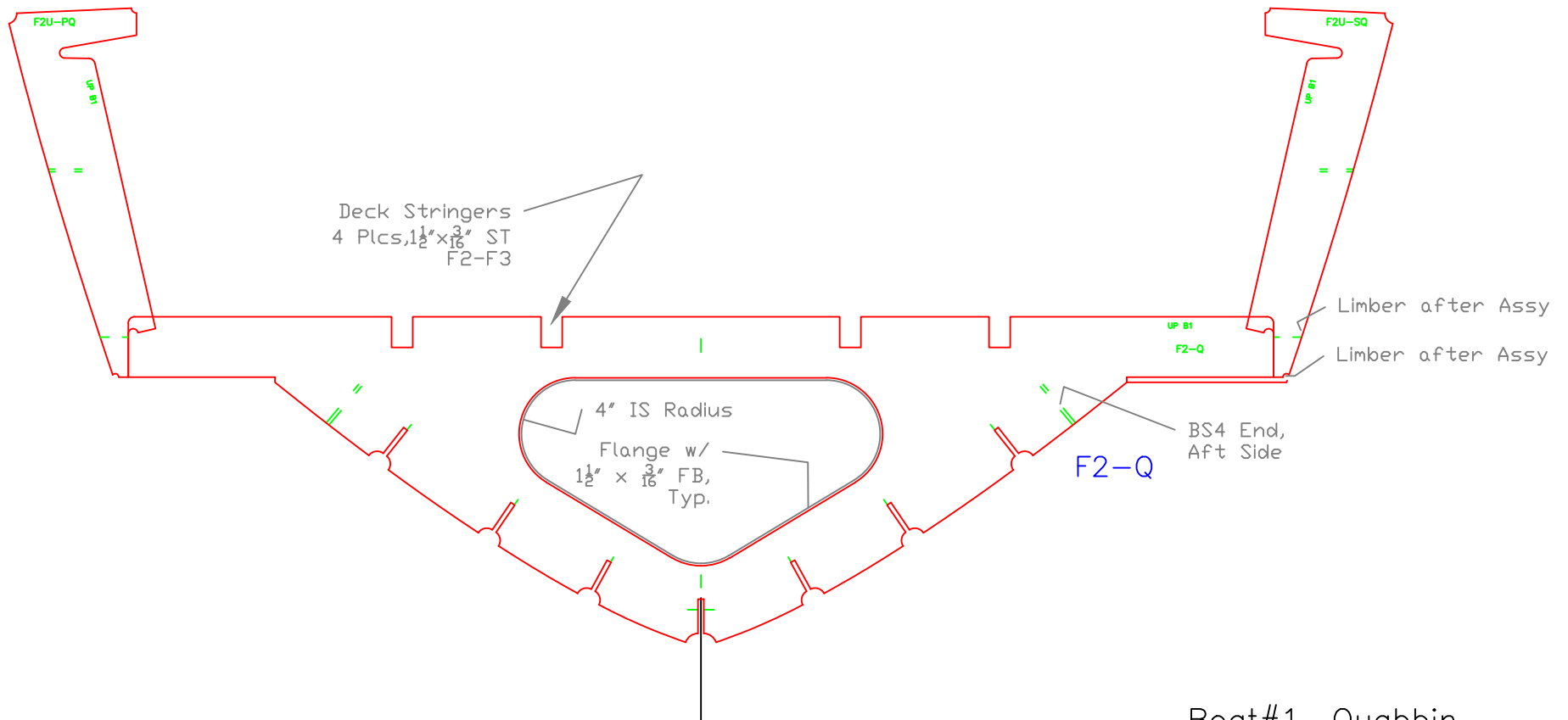

Boat#1, Quabbin

|   |                    |                     |
|---|--------------------|---------------------|
| FRAME 2                                 |                    |                     |
| Response #544-24'x9' BB                 |                    |                     |
| SCALE<br>1" = 1'                        | DES/DWN<br>WAL/JCC | DATE<br>4/3/17      |
| <b>Response Marine, Inc.</b>            |                    | SHEET               |
| Newburyport, MA, www.responsemarine.com |                    | DWG NO.<br>544-F-2Q |

| REV. | DESCRIPTION |
|------|-------------|
|      |             |

Install w/  
Marks & Flange on AFT Side

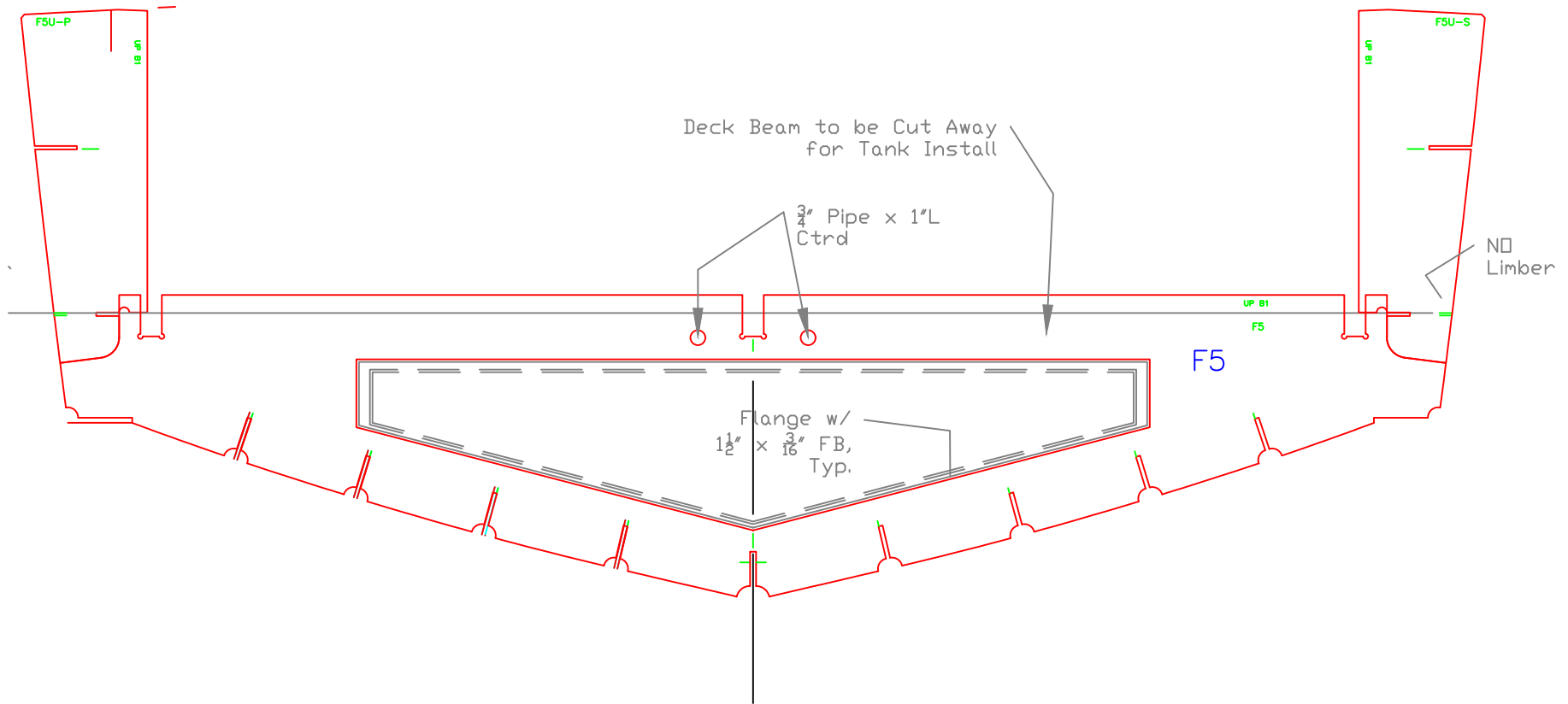

Quabbin & Wachusett

FRAME 5

Response #544-24'x9' BB

|                  |                    |                |
|------------------|--------------------|----------------|
| SCALE<br>1" = 1' | DES/DWN<br>WAL/JCC | DATE<br>4/3/17 |
|------------------|--------------------|----------------|

|                              |  |       |
|------------------------------|--|-------|
| <b>Response Marine, Inc.</b> |  | SHEET |
|------------------------------|--|-------|

|   |                    |
|---|--------------------|
| Newburyport, MA, <a href="http://www.responsemarine.com">www.responsemarine.com</a> | DWG NO.<br>544-F-5 |
|---|--------------------|

| REV. | DESCRIPTION |
|------|-------------|
|      |             |